



# NEXTSTATION-X

The intelligent, compact design of the NextStation-X allows for both easy transport and expandability. Its short 12" depth and rack mount options for front I-O or rear I-O access make it ideal for M&E production and live event use cases including broadcast trucks or other vehicles. It is ideal to use as a workstation for on-set production rendering, encoding, graphics editing, color correction, streaming, ISO recording, and more.

- High-performance processors from Ampere
- No-tools removable storage options include NVME, SAS/ SATA SSDs, and SATA 6G SSDs
- Includes Secure Boot UEFI compliant BIOS, Intel Boot Guard, TPM2.0 trusted Platform
- Certified for CentOS, Red Hat Enterprise Linux, VMware vSphere, Windows Server, Windows 11
- PCI Express expansion slots for purpose-built I-O configurations and FPGA or GPU co-processing
- Systems are stackable, cooling front to back
- Includes service and maintenance documents for easy field access, service, and installation of PCIe cards
- Compliant with the NextComputing Supply Chain Risk Management Process

**Smallest form factor, highest performance:** as a desktop or short depth rack mount

**Easily transportable:** System and hard case combined are less than 35lbs for single-person lift and as aircraft carry-on

**Modular and purpose-built:** Configure your power, storage, and expansion options for your specific high-performance use case

**High-performance workstation:** Ideal for rendering and scientific simulation

# NEXTSTATION-X

## SPECS

	Standard
Available CPUs	<ul style="list-style-type: none"> <li>AmpereOne® or Ampere® Altra®</li> </ul>
Memory	3200 MHz ECC RAM to 2TB
PCI Expansion	(7) PCI Express slots for ½ height PCI Express cards to ¾ length cards or 9" length
AI	Configurations available with up to (5) NVIDIA L4 Tensor Core GPU for Artificial Intelligence (AI)/machine learning at the Edge
Storage	<ul style="list-style-type: none"> <li>Up to (4) removable 2.5" NVME SSDs with capacities up to 15.36TB per SSD and 1 or 2 M.2 SSDs up to 4TB per module or 2 removable 2.5" SATA 6G SATA SSDs up to 4TB per SSD</li> <li>-or- up to (8) NVME 2.5" drives capacities up to 61.44TB per high endurance data processing and recording SSD (480TB) as JBOD or RAID 0/1/5/6 configurations</li> </ul>
RAID	Configuration options for up to (3) separate hardware RAIDs and multiple RAID array types including RAID 0, 1, 5, and 6 depending on use cases
Sustained Writes	<ul style="list-style-type: none"> <li>NVME to 3.3GB/Second per drive (2 drives total)</li> <li>12G SAS RAID 5 of 8 drives sustained at 6.3 GB Reads and 3.7 GB Writes</li> <li>6G SATA RAID 5 of 8 drives sustained 2.8 GB Reads / 2.6 GB Writes</li> </ul>
Network Interfaces	Single or multiple 1G, 10G, 25G and 100G network interface options
Security	Secure Boot UEFI compliant BIOS, Boot Guard, TPM2.0
Remote Management	HTML5 and API based out of band management with MAC addresses identification, one time boot on next reboot option, PXE boot option
Operating Systems	Operating Systems supported include: Windows 11, CentOS, Red Hat Enterprise Linux, VMware vSphere, Windows Server
Power	<ul style="list-style-type: none"> <li>750W 80 PLUS Titanium 110/220V 50/60HZ autoswitching</li> <li>850W 80 PLUS Titanium 110/220V 50/60HZ autoswitching</li> </ul>
Carrying Case	<p>Includes rugged airline carry-on case, small luggage form factor 10.60" H x 21.20" W x 16" D with telescoping handle &amp; wheels.</p> <p>Note that 100% TSA compliance is: 9.0" H x 22" W x 14" D and this hard case package is slightly over that dimension in Height and Depth but compliant in Width. It is likely this will be allowed as carry-on unless physical inspection performed to exact dimensions are done by the airline at the gate</p>
Physical	6.42" H x 17.65" W x 12.11" D. Complete solution including TSA carry-on compliant hard case range from 30 lbs to 45 lbs typically (single person lift)



Rugged carry-on case



Single-person lift, under <35 lbs total

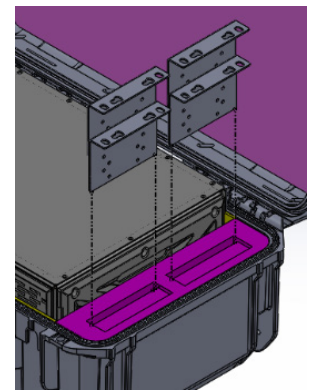

Removable rack mount ears store in case



4 Townsend West, Building 17, Nashua, NH 03063  
 Phone: 1 (603) 886-3874 • Fax: 1 (603) 886-1736  
[www.NextComputing.com](http://www.NextComputing.com) • [sales@Nextcomputing.com](mailto:sales@Nextcomputing.com)

# NEXTSTATION-X

## PHYSICAL

<b>Environmental</b>	<ul style="list-style-type: none"> <li>• 0°C–40°C / 32°F–104°F. Non-Operating: -20°C–70°C, -4°F–158°F.</li> <li>• Relative humidity (5-95%) non-condensing</li> <li>• FCC Class A, CE, TUV, ROHS, Conflict Minerals Free</li> </ul>
<b>Warranty</b>	1 year parts and labor. 2nd and 3rd year warranty options
<b>Ease of Service and Upgrade</b>	All storage is removable without tools. Easy access for install and removal of PCI Express cards. Easy to service other system elements. Modular design
<b>Purpose-Built Solutions</b>	Private label branding options. Purpose built application integration and configuration control management services.
<b>Mounting Configuration</b>	<p>The NextStation-X can be operated on a table top, front rack mounted, or front access I-O rack mounted. Rack mounting can be done via only (2) rack mount ears or (4) rack mount ears (front and back).</p> <p><i>For vehicle and truck mount use all 4 rack ears front and back</i></p>



Front I-O rack option

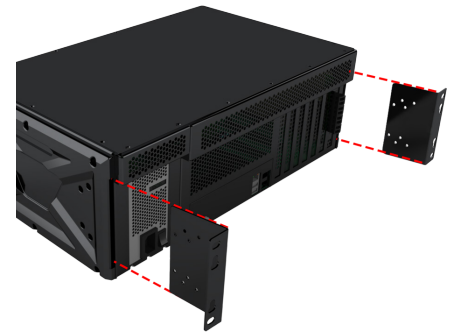

Rear I-O rack option

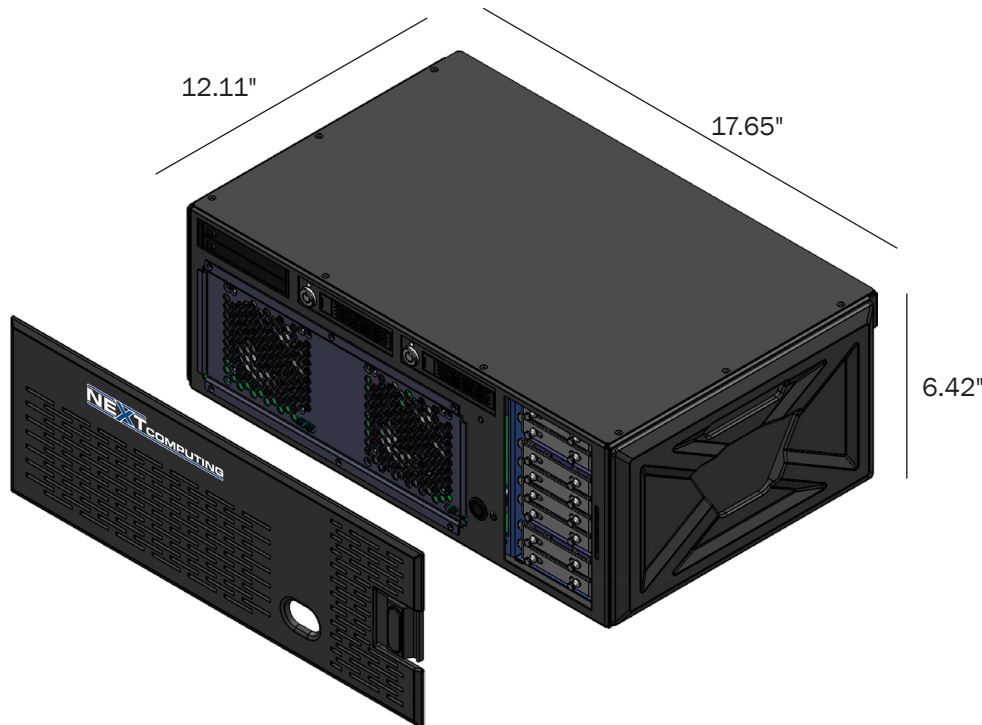

- Short depth 12.11" for rack mount
- Small footprint for desktop (includes rubber feet)
- Stackable on the desktop and cooling front to rear
- Grip-able side bezels and lightweight to carry
- Not tools removable front bezel to access removable SSDs

# NEXTSTATION-XL

Ask your NextComputing Sales Engineer about the NextStation-XL; An extended version of the NextStation-X with a deeper chassis designed to support high-end NVIDIA RTX GPUs for server/GPU co-processing.



4 Townsend West, Building 17, Nashua, NH 03063  
 Phone: 1 (603) 886-3874 • Fax: 1 (603) 886-1736  
[www.NextComputing.com](http://www.NextComputing.com) • [sales@Nextcomputing.com](mailto:sales@Nextcomputing.com)